

# Nº 626

STEREO PREAMPLIFIER OWNER'S MANUAL



mark  LEVINSON®

## TABLE OF CONTENTS

INSTALLATION CONSIDERATIONS	1
Unpacking, Placement and Ventilation, Power Requirements, Operating States	
SPECIAL DESIGN FEATURES	2
Analog Architecture, Digital Architecture, Construction, Key Features	
GETTING TO KNOW THE MARK LEVINSON N° 626	4
Front Panel Overview, Rear Panel Overview, Remote Control Overview, Battery Installation	
QUICK SETUP AND LISTEN	10
Remote Control, Initial Connections, Initial Connections Diagram	
SETUP MENU	12
Navigation, Input Setup, Audio Setup, System Setup	
HELPFUL HINTS	19
Determining the Load for the Phono Input, Renaming Inputs	
SURROUND SOUND PROCESSOR (SSP) MODE	20
CHOOSING A DIGITAL TO ANALOG CONVERSION FILTER	22
TROUBLESHOOTING	24
MARK LEVINSON N° 626 SPECIFICATIONS	26

## ABOUT THIS DOCUMENT

This **Owner's Manual** is designed to guide you through every facet of your **Mark Levinson N° 626 Dual-Monaural Preamplifier**, from initial installation and system setup to everyday operation and advanced personalization. Its aim is to ensure that you experience the full potential of the **N° 626**, enabling the highest levels of musical performance, intuitive control, and long-term satisfaction with your audio system

# INSTALLATION CONSIDERATIONS

## UNPACKING

When unpacking your **preamplifier**:

- o Save all packing materials in case you need to ship your **preamp** in the future.
- o Inspect your **preamp** for signs of damage during shipment. If you discover damage, contact your authorized **Mark Levinson** dealer for assistance in making appropriate claims.
- o Retain your original, dated sales receipt as proof of warranty coverage.
- o Remove the **accessory box** from the shipping **carton**. Make sure that all of the **items** listed below are included. If any are missing, contact your authorized **Mark Levinson dealer**.

- » 1x Mark Levinson® N° 626 dual-monaural preamplifier
- » 1x Full Function IR Wireless Remote Control
- » 2x AAA Batteries for Remote Control
- » 1x Quick Start Guide
- » 1x IEC power cord (terminated according to the region to which the unit is shipped)
- » 1x Micro-fiber polishing cloth
- » 1x Safety Booklet

## PLACEMENT AND VENTILATION

- o Install the **preamplifier** on a shelf with several inches of clearance above it to ensure proper ventilation. Do NOT install the preamplifier inside of an enclosed cabinet or rack.
- o Ensure that you install the **preamplifier** on a solid, flat and level surface.
- o Install the **preamplifier** as close as possible to associated audio components to keep interconnecting cables as short as possible.
- o Select a dry, well-ventilated location that is out of direct sunlight.
- o DO NOT expose the **preamp** to high temperatures, humidity, steam, smoke, dampness, or excessive dust.
- o DO NOT block **chassis ventilation holes**.

## POWER REQUIREMENTS

The preamplifier is configured at the factory for 100, 120, or 230 VAC power operation at 50Hz or 60Hz. Before operating, ensure that the power label on the rear panel near the AC input connector indicates the correct operating voltage. A detachable IEC power cable intended for use in the region where the unit is sold is included.

Connection to an AC voltage other than that for which the unit is intended can create a safety and fire hazard and may damage the unit. If you have any questions about the voltage requirements for your preamplifier or about the line voltage in your area, contact your authorized Mark Levinson dealer before plugging the unit into an AC power outlet.

**WARNING! MAKE SURE all components in the audio system are properly grounded. Do NOT defeat the safety purpose of polarized or grounding-type plugs with “ground-lifter” or “cheater” adapters. Doing so may cause dangerous voltage to build up between components, which may result in personal injuries and/or product damage.**

You should unplug the preamplifier from the AC wall outlet during lightning storms and extended periods of non-use.

**CAUTION: BEFORE moving the unit, make sure it is powered off by removing the power cord from the AC power outlet and the unit’s rear panel.**

## OPERATING STATES

The preamplifier has three operating states:

**OFF:** The AC mains power is disconnected by using the rear-panel Power switch or by removing the power cord from the rear panel.

**ON:** The entire unit is powered up and all configured outputs are active.

**STANDBY:** The Standby mode has two settings that can be selected via the Setup Menu: **ECO On** and **ECO Off**. Power consumption in **ECO On** Mode Standby mode is < 0.5W.

**Note:** The preamplifier ships in **ECO On** Mode by default, a feature that automatically places it into the **Standby mode** after 20 minutes of no user control input or audio signal passing through the unit. If this mode is disabled in the **Setup** Menu, it will result in increased power consumption.

## SPECIAL DESIGN FEATURES

### SPECIAL DESIGN FEATURES

Thank you for selecting the Mark Levinson № 626 Stereo Preamplifier. Every component in the **Mark Levinson 600 Series** is meticulously crafted to reveal the full depth, dimension, and emotional impact of recorded music—elevating the listening experience into a true art form. The **№ 626** represents the culmination of more than fifty years of engineering expertise and six generations of continuous analog and digital refinement. Each model is not only an example of precision engineering and timeless industrial design, but also a statement of our commitment to purity, performance, and longevity. Created for listeners who demand uncompromising sound quality combined with an elegant aesthetic, the **№ 626** embodies a rare balance between artistic expression and advanced technology. After reviewing this owner's manual, should you have any questions regarding operation, installation, or the advanced capabilities of your **№ 626 Stereo Preamplifier**, our **Customer Support Team** is ready to assist you at:

[support.harmanluxuryaudio.com](http://support.harmanluxuryaudio.com)

### ANALOG ARCHITECTURE

At the heart of the **№ 626** stereo preamplifier is **Mark Levinson's** proprietary **Pure Path** design philosophy. It is built upon a discrete, direct coupled, fully balanced, dual-monaural signal path design featuring a discrete, balanced R-2R ladder volume control. It includes individual audio signal switching relays for each of the six pairs of **analog stereo inputs** that include: **two balanced pairs (XLR), three single-ended pairs (RCA), and a Mark Levinson Class A phono stage (RCA) with ground**. All analog audio is processed and contained on a separate circuit board that is physically decoupled from the power supply and the digital audio & control board. This ensures the protection of the delicate analog audio signals from input to final output.

The **№ 626's R-2R ladder volume control** architecture utilizes discrete (separate sets for left and right) precision resistors and analog switches for extremely accurate, balanced volume steps to deliver wide bandwidth and maximum signal integrity with no mechanical wear, ensuring consistent sound quality across all

volume levels, as well as years of reliable service. When matched with a high efficiency speaker system and no incoming source signal, you may be able to hear a very low level "tick" as the **R-2R ladder volume control** moves up or down the volume scale. This is a normal functional artifact.

For system integration and expansion, the **№ 626** offers **balanced (XLR) and single-ended (RCA) analog audio outputs** that can operate full-range or with a switchable **4th-order 80Hz high-pass filter** employed, enabling seamless integration with powered subwoofers.

### CLASS A HEADPHONE AMPLIFIER

The **№ 626 Stereo Preamplifier** incorporates a dedicated **Main Drive™ Class A headphone amplifier** designed to deliver uncompromised personal listening performance directly from the **Pure Path analog signal architecture**. Fully discrete, direct-coupled, and fully balanced, the headphone output provides exceptional current capability, enabling a wide range of high-performance headphones to be driven directly without the need for an external amplifier. Operating in pure Class A, the **Main Drive™ circuit** preserves harmonic accuracy, dynamic expression, and low-level detail with remarkable transparency. The result is a refined and immersive listening experience that faithfully reflects the musical purity, resolution, and realism of the **№ 626's main analog outputs**.

### DIGITAL ARCHITECTURE

Building upon the superb **Mark Levinson** analog platform, the **№ 626** adds an equally outstanding digital audio platform. Housed on a single, dedicated circuit board and appropriately shielded from the analog and power supply boards is the digital audio / control board with six digital stereo audio inputs that include: one asynchronous USB-C, one AES/EBU (XLR), two coaxial (RCA), and two optical (Toslink®) connections.

At the heart of the digital audio platform is the new **Mark Levinson PrecisionLink III D/A converter**, our third generation in digital

to analog converters. At the foundation of the design is the **ESS 9039SPRO**, a **32-bit / 8-channel Hyperstream® IV DAC** with proprietary jitter elimination circuitry, fully balanced circuit design, and independent power supply. The **Mark Levinson** design delivers extremely accurate, low-noise conversion of digital music to analog signals with an incredible **+132dB dynamic range**. The new **PrecisionLink III** design supports high-resolution digital audio signals up to **32-bit/384kHz PCM** and **DSD512** natively (USB-C) to satisfy the most demanding audiophile needs. Each digital input offers **7 user-selectable filters** allowing the most discerning listeners to tune the **D/A filters** to their own personal taste or to the character of the content.

System integration and communication ports include one **IR input**, one **12V trigger input** / two **12V trigger outputs**, one **RJ12 Link** (Future Use), and one **USB-A port** (Service Only). A system **IR remote control** is included for general operation and set-up adjustments.

## CONSTRUCTION

Each component in the **600 Series** is hand-crafted in the dramatic new **Tectonic design language** that was inspired by the majestic beauty and power of the Earth's tectonic volcanism. Its monolithic form reflects the brand's heritage, with an interplay of brushed metal, deep glass, and the subtle implementation of C2 continuity design of control surfaces evoking the timeless confidence of a precision instrument. The **Tectonic exterior** features a **chassis of aluminum and steel** anodized in black with silver **anodized controls**. A **glass center panel accented with red lighting** on either side forms the focal point of the front panel. The **top panel** includes the **glass Core element** with **red accent lighting** surrounded by generous **ventilation** for maximum thermal efficiency.

The chassis of the **Nº 626** utilizes a modular architecture that isolates low-level analog and digital circuitry from the power supply with critical components isolated on rubber mounts. The **Nº 626** also utilizes **Mark Levinson's** latest **vibration-damping, mechanically isolated foot design** to provide the most stable and decoupled connection from the surface upon which it sits.

## KEY FEATURES

- **Mark Levinson proprietary discrete, direct coupled, fully balanced, dual-monaural signal path topology**
- **Discrete, balanced R-2R ladder volume controls**
- **Digital inputs: one Asynchronous USB-C, one AES/EBU balanced (XLR), two Toslink® (Optical), and two Coaxial (RCA)**
- **Analog inputs: two balanced (XLR), three single-ended (RCA), and one Moving Magnet or Moving Coil single-ended phono pair (RCA) with ground pin**
- **Analog outputs: XLR balanced pair, RCA single-ended pair, and a 1/4-inch (6.3mm) headphone**
- **Supports high-resolution formats up to 32-bit / 384kHz PCM (all digital inputs) and quad-speed DSD512 (Asynchronous USB-C input)**
- **Mark Levinson PrecisionLink III DAC featuring the renowned ESS 9039SPRO processor**
- **Seven user-selectable DAC filters for tailored digital performance**
- **Selectable phono stage for moving coil or moving magnet cartridges with selectable gain, infrasonic filter, resistive and capacitive-loading settings (adjustable options vary depending on cartridge type)**
- **Selectable output with fourth-order, 80 Hz high-pass filter allows seamless integration of subwoofer**
- **Full-function, aluminum chassis, infra-red wireless remote control**
- **Mark Levinson tectonic inspired, precision-tooled aluminum and steel industrial design highlighting a classic Mark Levinson signature, large dot-matrix red display with variable brightness and accent lighting controls**
- **Designed and engineered in the USA**

## GETTING TO KNOW THE MARK LEVINSON N° 626

### FRONT PANEL OVERVIEW

1. Input Source/Parameter Selection
2. 16-Character Hi-Res Dot-Matrix Display
3. Setup
4. Enter
5. IR Window
6. Function
7. Mute/Unmute
8. Volume/Parameter Adjustment
9. Vibration-damping, Mechanically Isolated Foot Bars
10. Standby On/Off
11. Headphone Output

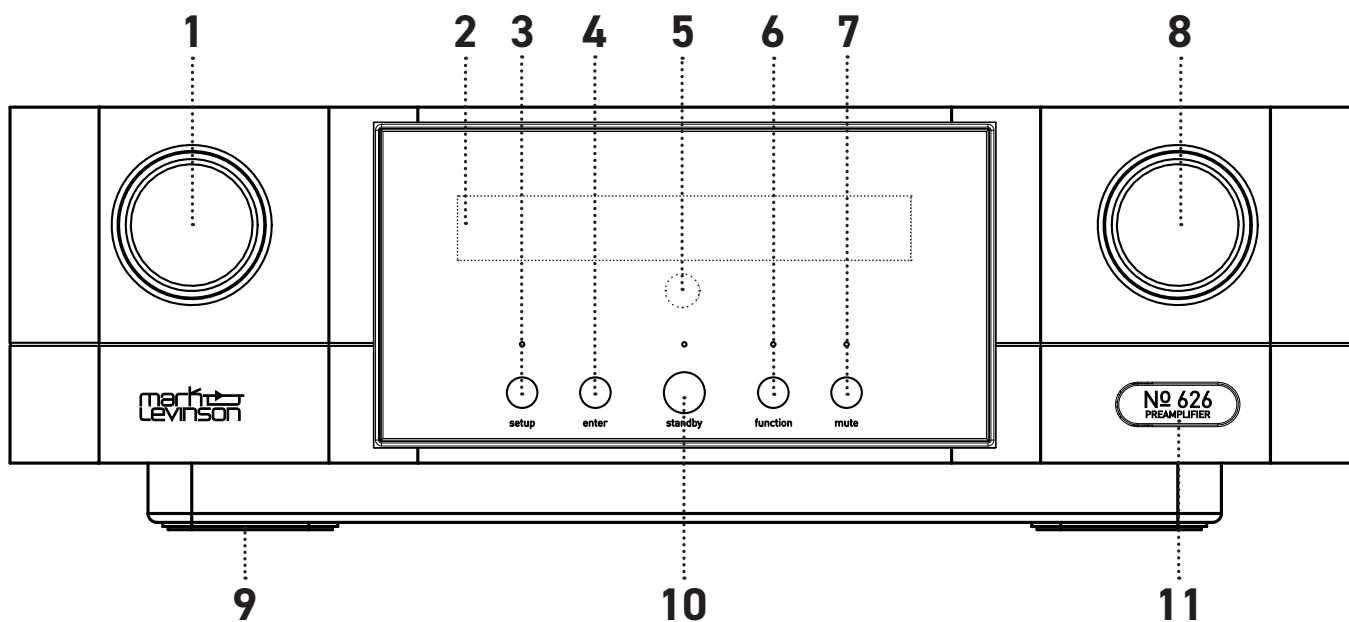

**1. INPUT SOURCE/PARAMETER SELECTION:** Rotate this knob to select the desired input source. The name and volume level of the selected input are indicated on the display. When the **Setup** button has been pressed, rotate this knob to scroll through the menu items and use the **Enter** button to select an item.

**Note:** the Input knob will bypass any input for which the **Input Name** parameter has been set to **Disabled**.

**2. 16-CHARACTER HI-RES DOT-MATRIX DISPLAY:** Part of the traditional **Mark Levinson** design language for generations, this large dot-matrix display is easily readable from across the room and tells you what you need to know about the current state of the **N° 626**.

**3. SETUP:** Press this button to display the **Setup** Menu, which you can use to customize the preamplifier to suit your preferences.

**4. ENTER (MENU SELECTION):** When navigating the **Setup** Menu, use the **Enter** button to select menu items, which include submenus and parameters. When a parameter has been selected using the **Enter** button, the value can be adjusted using the **Volume knob** and saved/confirmed by pressing the **Enter** button once more.

**5. IR WINDOW:** The IR receiver receives commands from the included remote control when the unit is not being controlled via its rear-panel **IR Input** connector (see Rear-Panel Overview for more information).

**Note:** Infrared communication requires line-of-sight between the remote and this “target” on the unit’s front panel.

**6. FUNCTION:** Press this button to activate the assigned function. **Balance** (default), **Polarity**, or **Display Brightness** can be assigned in the **Setup** Menu.

**7. MUTE BUTTON:** Press this button to mute and unmute the **Balanced outputs** and the **Single-Ended outputs** if you have set them to **Variable** in the **Setup** Menu. The amount of attenuation selected in the **Setup** Menu will determine the output level when muted (full or partial mute). If headphones are connected, the **Mute** button will mute the level of the **Headphone output** according to the **Headphone Mute** menu setting. The **Mute LED** on the front panel is lit when the mute function is active.

**8. VOLUME/PARAMETER ADJUSTMENT:** Rotate this knob to adjust the volume level of the **Balanced outputs** (and the **Single-Ended outputs** if you have set them to **Variable** in the **Setup** Menu). When headphones are connected, the **Volume knob** will adjust the level of the **Headphone output** independently from the system master volume. The minimum volume level is **OFF**, and the maximum volume level is determined in the **Setup** Menu.

Whenever an input is selected, the unit applies the volume offset selected for it in the **Setup** Menu to the **Main output volume level** (and to the **Line output volume level** if you have set it to **Variable** in the **Setup** Menu).

**Note:** The balanced and single-ended outputs can be configured as **Fixed** in the **Setup** Menu (for use with recording components or a second audio zone). When outputs are configured as **Fixed**, they are not affected by any of the front-panel controls.

**9. VIBRATION-DAMPING, MECHANICALLY ISOLATED FOOT BARS:** Mechanically isolated foot bars decouple the **N° 626** from its surroundings, minimizing the transfer of micro-vibrations in and out of the unit.

**10. STANDBY:** Press this button to put the unit into and out of **Standby** mode. The **LED** is brightly illuminated red when the unit is **On**. When the unit is in **Standby** mode, the **LED** is dimly illuminated red.

**Note:** If this **LED** is illuminated white, please see the troubleshooting section of this manual and/or contact customer support or your local dealer as this indicates a fault condition.

**11. HEADPHONE OUTPUT CONNECTOR:** Hidden behind the **N° 626 Preamplifier badge**, this ¼-inch (6.3mm) **TRS phono plug connector** provides access to a powerful **Class-A headphone amplifier**. To access the headphone connector, press inward on the left edge of the **N° 626 Preamplifier badge**.

The **Headphone circuit** supports both independent volume and independent balance functions as compared to the main system values for volume and balance. When the unit detects that headphones have been connected, the **Balanced and Single-Ended outputs** are automatically muted, and the **Volume knob** will control the **Headphone output level**. When the unit detects that the headphones have been disconnected, the **N° 626** will automatically return to normal operation, unmuting the **Balanced and Single-Ended outputs** and returning the volume control to the user-specified configuration.

## REAR PANEL OVERVIEW

1. **Right Channel Line Outputs:**  
1x balanced XLR, 1x RCA
2. **Right Channel Analog Inputs:**  
2x balanced XLR, 3x RCA
3. **Phono Input:**  
2x RCA (Right, Left, Ground)
4. **Left Channel Analog Inputs:**  
2x balanced XLR, 3x RCA
5. **Left Channel Line Outputs:**  
1x balanced XLR, 1x RCA
6. **Digital Inputs:**  
1x USB-C, 1x AES/EBU, 2x RCA, 2x TosLink
7. **Control:**  
1x 3.5mm IR In, 1x RJ12 (Link),  
1x 3.5mm 12V Trigger In,  
2x 3.5mm 12V Trigger Out
8. **Software Update:**  
Use if needed for firmware updates (USB-A)
9. **Mains Power Plug & Mains Power Switch:**  
IEC power cord included  
**Mains Power Switch:**  
Connect/disconnect from power source

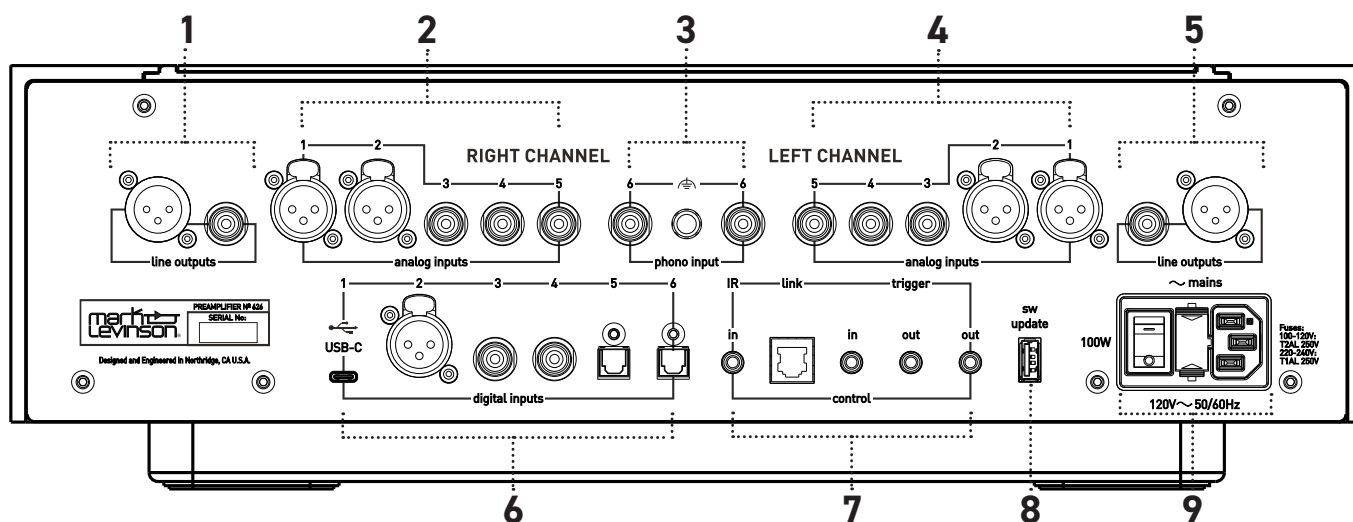

### OUTPUT CONNECTORS (1,5):

**BALANCED OUTPUT CONNECTORS:** These **XLR 3-pin connectors** provide a line-level left-channel and right-channel signal that can be used to send the selected source to power amplifier inputs, a powered subwoofer, or recording components. **Mark Levinson** recommends using the **Balanced outputs** as the primary output if your amplifiers offer balanced inputs.

**SINGLE-ENDED OUTPUT CONNECTORS:** These **RCA connectors** provide a line-level left-channel and right-channel signal that can

be used to send the selected source to amplifier inputs, a powered subwoofer, a second listening zone, or recording components.

### ANALOG INPUT CONNECTORS (ANALOG = 2, 3, 4)

**BALANCED ANALOG INPUT CONNECTORS (2, 4):** These connectors accept left-channel and right-channel balanced input signals from source components with balanced (male XLR) output connectors. **Mark Levinson** recommends using balanced connections whenever possible.

**SINGLE-ENDED INPUT CONNECTORS (2, 4):** These connectors accept left-channel and right-channel single-ended (unbalanced) input signals from source components without balanced output connectors. **Mark Levinson** recommends using balanced connections whenever possible.

**PHONO INPUT CONNECTORS (3):** These connectors accept left-channel and right-channel single-ended (unbalanced) input signals from turntables with moving-magnet or moving-coil cartridges that do not have a built-in preamplifier. Connect the turntable output cable's grounding terminal to the preamplifier's ground pin by loosening the threaded collar, inserting the terminal, and tightening the collar using your fingers only. Do not tighten the ground pin collar with tools (do not overtighten).

**ANALOG OUTPUT CONNECTOR CONFIGURATION (1, 5):** By default, the **Balanced and Single-ended outputs** are configured in the **Setup Menu** as **Variable**. When so configured, the **Balanced and Single-Ended outputs** will follow the settings of the **Volume, Balance** and **Mute** controls. The **Headphone output** is always **variable**.

The **Balanced and Single-ended outputs** can also be configured in the **Setup Menu** as **Fixed** (for use with recording components or a second audio zone).

**WARNING:** This sets the output level to Volume Level 67 (unity gain) and prevents volume changes by the user. Careful use of this mode is required to avoid damage to your audio system.

Additionally, if you would like to include a powered subwoofer in your system, you can restrict the low frequencies sent to your main speakers by engaging the unit's **24dB-per-octave Linkwitz-Riley 4th-order 80Hz high-pass filter**, which can be applied to either the **Balanced or Single-Ended outputs**.

For further information on configuring these parameters, see the **Audio Setup Menu** section of this manual.

### **DIGITAL INPUT CONNECTORS (6):**

The **N° 626** has six digital audio input connectors:

**1 X USB TYPE C (ASYNCHRONOUS):** For playback of high resolution files up to 32-bit/384kHz, connect to any compatible source device. For native DSD playback up to DSD512, this input can be used to stream music from a Linux or Android-based source device.

**1 X AES/EBU BALANCED XLR**

**2 X COAXIAL S/PDIF RCA**

**2 X OPTICAL S/PDIF TOSLINK**

### **CONTROL CONNECTORS (7)**

**LINK CONNECTOR:** This connection is reserved for use with future **Mark Levinson** products.

**IR INPUT CONNECTOR:** This **1/8-inch (3.5mm)** connector accepts IR (infrared) control signals from other equipment (see trigger illustration below).

**TRIGGER OUTPUT CONNECTORS:** These **1/8-inch (3.5mm) TS phone plug connectors** can be used to activate other components in the audio system and listening room, such as amplifiers, lights, and window shades. A 12V 100mA DC signal is output whenever the unit is on. The trigger can also be pulsed and delayed. (See illustration).

Trigger phone plug connector pin assignments:

- Tip: +
- Sleeve: -



**TRIGGER INPUT CONNECTOR:** This **1/8-inch (3.5mm) TS phone plug connector** can be connected to the trigger output of another system.

**Balanced connector pin assignments:**

- Pin 1: Signal ground
- Pin 2: Signal + (non-inverting) "hot"
- Pin 3: Signal - (inverting) "cold"

Balanced Input Connector (female XLR)



Balanced Output Connector (male XLR)

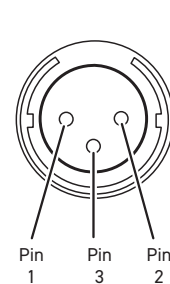

### **USB TYPE-A CONNECTOR (8)**

This connector is for attaching a USB flash drive containing software updates. Further information and details on software updates are delivered with any new software release and can be found in the **Documents & Downloads** section of the product's web page at [www.marklevinson.com](http://www.marklevinson.com).

## REMOTE CONTROL OVERVIEW

- A. Device Control Selection  
(LED reflects selected device)
- B. Standby On/Off
- C. Setup  
(press to enter device Setup Menu)
- D. Home  
(return to home menu of device)
- E. Function  
(user assignable quick recall button)
- F. Menu Navigation Controls  
(up/down/left/right)
- G. Menu Selection Button (enter)
- H. Volume Adjustment
- I. Mute/Unmute
- J. Last Track/Rewind
- K. Play/Pause
- L. Next Track/Fast-Forward
- M. Display Settings
- N. Stop/Eject
- O. Info

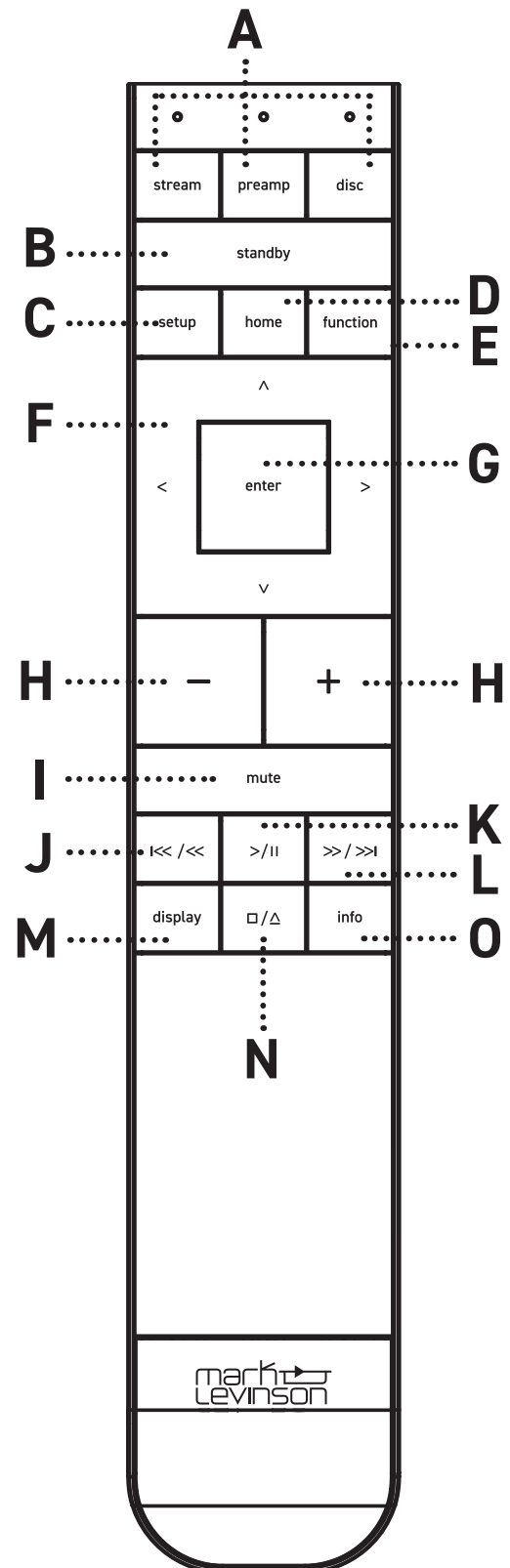

**A. DEVICE CONTROL SELECTION:** Press these buttons to select which device the remote control commands. Choose between **streamer**, **preamp**, or **disc player**.

Select **Preamp** to control the **N° 626**.

**B. STANDBY:** Press this button to put the unit into **Standby** and to wake the unit from the selected **Standby** mode.

**C. SETUP:** Press this button to display the **Setup** Menu, which you can use to customize the preamplifier to suit your preferences. The front panel illuminates when the **Setup** Menu is active.

**D. HOME:** Press this button to return to the normal status display.

**E. FUNCTION:** Press this button to activate the assigned function. **Balance**, **Polarity**, or **Display Brightness** can be assigned in the **Setup** Menu.

**F. MENU NAVIGATION:** During Normal Operation: Press **Up/Down** to change the input source or **Left/Right** to adjust the balance.

When Setup Menu is active: **Up/Down** scroll through parameters, and **Left/Right** adjust parameters after **Enter** has been pressed. Press **Enter** again to save the parameter value.

**G. MENU SELECTION (ENTER):** When navigating the **Setup** Menu, use the **Enter** button to select menu items, which include submenus and parameters. When a parameter has been selecting using the **Enter** button, the value can be adjusted using **Left/Right** and saved/confirmed by pressing the **Enter** button once more.

**H. VOLUME BUTTONS:** Press these buttons to increase (+) or decrease (-) the volume level of the **Balanced outputs** (and the **Single-Ended outputs** if you have set them to **Variable** in the **Setup** Menu). If headphones are connected, the **Volume** buttons will adjust the level of the **Headphone** output. The minimum volume level is OFF, and the maximum volume level is determined in the **Setup** Menu. Whenever an input is selected, the unit applies the volume offset selected for it in the **Setup** Menu to the **Main output** volume level (and to the **Line output** volume level if you have set it to **Variable** in the **Setup** Menu).

**I. MUTE BUTTON:** Press this button to mute and unmute the **Balanced outputs** and the **Single-Ended outputs** if you have set them to **Variable** in the **Setup** Menu. The amount of attenuation selected in the **Setup** Menu will determine the output level when muted (full or partial mute). If headphones are connected, the **Mute** button will mute the level of the **Headphone output** according to the menu setting. The **Mute LED** on the **front panel** is lit when the mute function is active.

**J, K, L, N. TRANSPORT CONTROLS:** These buttons control playback of future **Mark Levinson** source devices. The corresponding device selection must be made on the remote (see **A.**).

**Last Track/Rewind:** Single-click this button to return to the previous track. Click and hold to rewind.

**Play/Pause:** Press this button to pause the currently playing track. When a track is paused, press this button to resume playback.

**Next Track/Fast-Forward:** Single-click this button to skip to the next track. Press and hold to fast-forward.

**Stop/Eject:** Press this button once to stop a connected disc player/streamer. Press a second time to eject a disc.

**M. DISPLAY:** Press this button to change the intensity of the front-panel display. Multiple presses of the **Display** button cycle through the available brightness levels: **High**, **Medium**, **Low**, **Off**. If the display is Off and the unit is On, press the **Display** button to turn the display on.

**O. INFO:** Press once to show the current input in relation to the physical input. Press again to display track resolution for digital inputs.

## BATTERY INSTALLATION

1. Press and hold
2. Slide to release battery compartment door

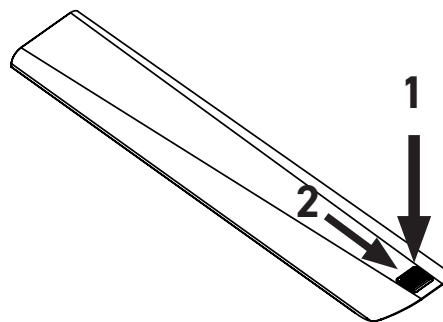

3. Insert 2x standard AAA batteries, observing correct battery polarity

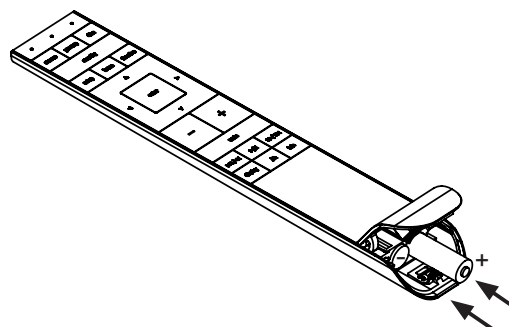

## QUICK SETUP AND LISTEN

### REMOTE CONTROL

Your **remote control** comes with two AAA alkaline batteries. To install or replace the batteries, follow the instructions in the **Remote Control Overview** page.

When using the **remote control**, aim it toward the **front-panel IR receiver**. Make sure that no objects, such as furniture, block the remote's view of the receiver. Bright lights, fluorescent lights, and plasma video displays may interfere with the function of the remote.

The **remote** has a range of about 17 feet (5m), depending on the lighting conditions.

You can use the **remote** at an angle of up to 45°.

Placing the **preamplifier** behind tinted glass will reduce the **remote control's** effective range.

Reminder: There is an **IR input** on the **back panel** to allow for a remote IR sensor to be connected.

### INITIAL CONNECTIONS

**CAUTION:** Before making connections, make sure the preamplifier and all associated components are powered off and disconnected from electrical outlets.

1. Connect your amplifier(s) to the preamplifier's output connectors. **Mark Levinson** recommends using the **Balanced output connectors** if your amplifier(s) have balanced input connectors. Otherwise, use the **Single-ended output connectors**.
2. Connect analog source components' outputs to the preamp's analog audio inputs. **Mark Levinson** recommends using **Balanced connections** whenever they are available.
3. Connect **digital source components' outputs** to the **preamp's digital audio inputs**.  
**Note:** for DSD playback via the **USB-C input**, only Linux or Android-based source devices are supported.
4. Connect your speakers to your amplifier. Individual 4mm banana connectors should not be used in certain regions due to safety concerns. **Mark Levinson** recommends using spade connectors to terminate audio cables.

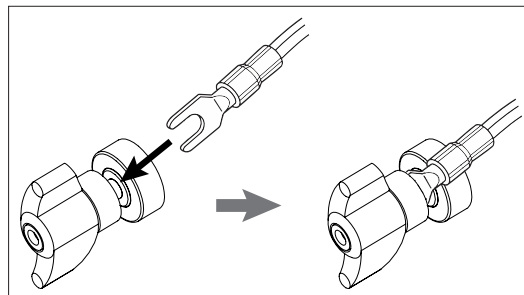

5. Connect the **supplied power cable** to the **preamp's AC Mains connector** and into an **electrical outlet**. Turn the **rear-panel Power switch** on the preamp to **On**, and turn on all associated components.
6. Make sure the **preamp's volume** is set to a reasonable level. It is best to start low and turn up to avoid unintentionally damaging your equipment. Begin playing the selected source device.
7. Press the front-panel **Standby button** or the **Standby button** on the **remote control**.
8. Turn the **Input knob** or press the **Input buttons** on the **remote** to select the **input** that corresponds to an **input connector** to which you connected a source component.

# INITIAL CONNECTIONS DIAGRAM

ENGLISH

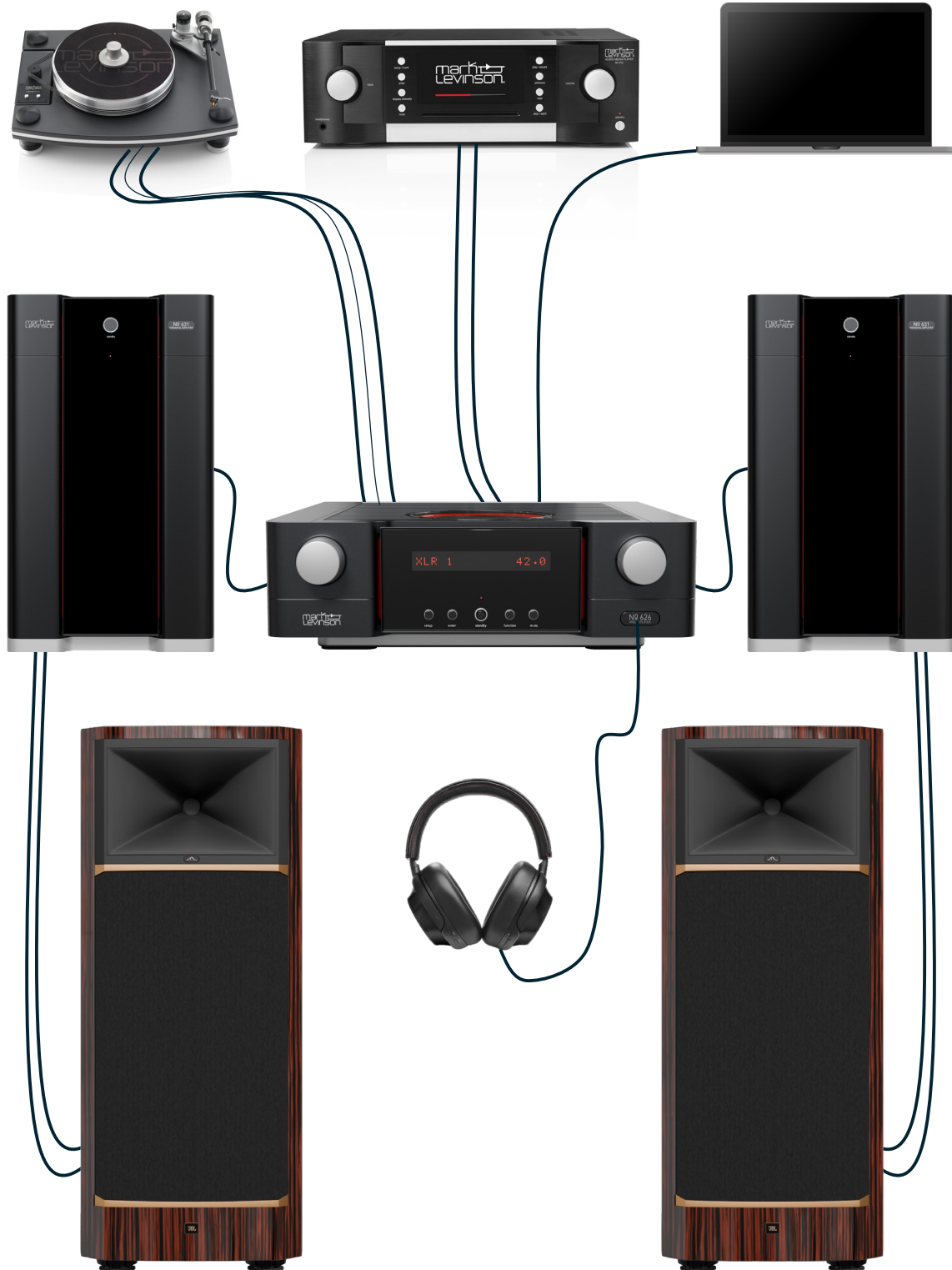





# SETUP MENU

## NAVIGATION

Pressing the **Setup** button displays the **Setup Menu** on the preamplifier's front-panel display.



### When the Setup Menu is active:

<p><b>TO SCROLL:</b> Use the <b>Input knob/remote (up/down)</b>.</p> 	<p><b>TO SELECT/SAVE:</b> Use the <b>Enter</b> button to select/save a <b>setting</b>. Most settings require pressing <b>Enter</b> to save changes that have been made.</p> 
<p><b>TO ADJUST PARAMETERS:</b> Use the <b>Volume knob/remote (left/right)</b>. "=" will flash when parameter has been selected and is adjustable.</p> 	<p><b>TO GO BACK:</b> Press the <b>Setup</b> button to move up a level in the menu. Press the <b>Home</b> button to exit the <b>Setup Menu</b> completely.</p> 

**Note:** During menu navigation, a flashing "=" indicates that a parameter is actively ready to be adjusted.

If the menu item has a solid "=", it indicates that either an item that can be selected for adjustment using the **Enter button** or that the menu item is not of a configurable type (for example, the firmware version).

## INPUT SETUP

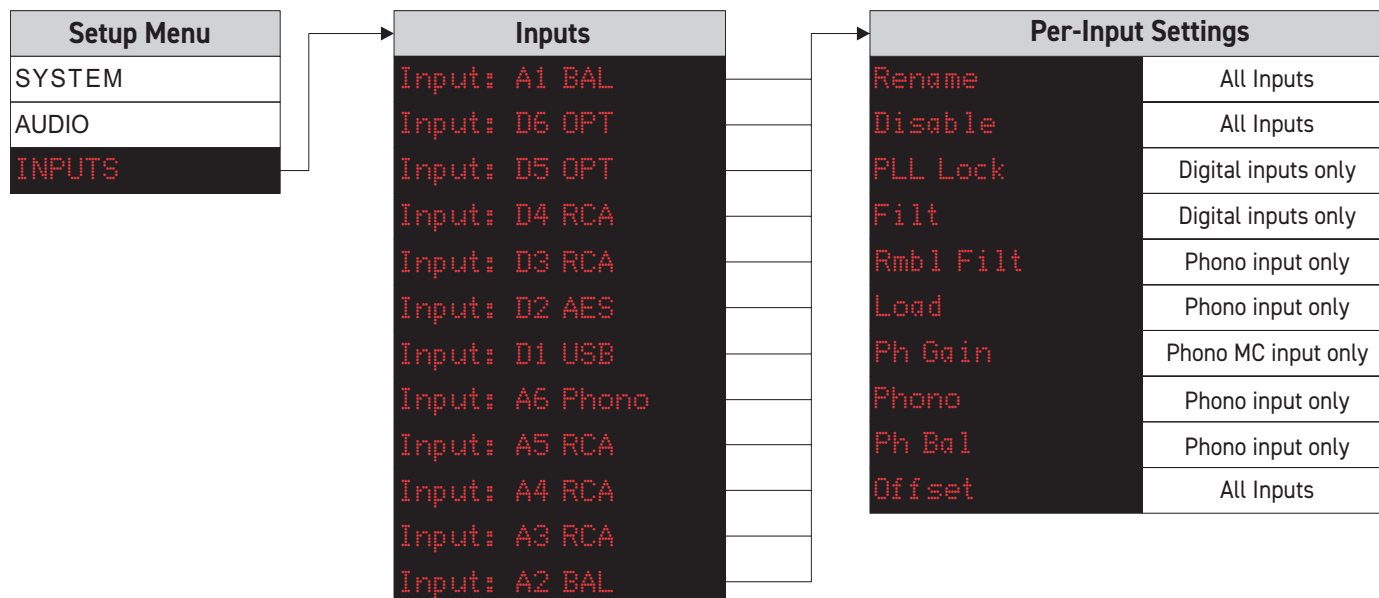

**RENAME:**

Allows each **input name** to be renamed by selecting from a list of standard names, creating a custom name, or resetting to the default name. See the **Helpful Hints** section on page 19 for additional information on the renaming process.

**DISABLE:**

Allows any input to be disabled. When **Yes** is selected, that input will not be visible or selectable via the **front panel input encoder or the remote control**. The default setting is **No**.

**OFFSET:**

Adjust the gain of an individual input by 0.5dB increments (+/- 6dB total range). This allows for precise volume-level matching between inputs. The default setting is "**+0.0**".

**PHONO:**

**MC** - For Moving Coil type cartridges (default setting)

**MM** - For Moving Magnet type cartridges

**Note:** This setting will affect the availability of certain options in the R Load, C Load, and Gain submenus.

**PH GAIN (MC ONLY):**

Determines the gain of the phono input stage. The options are **High** (default, 70dB) and **Low** (60dB).

**PH BAL:**

Adjusts the **L/R balance** of the **phono input** in steps of 0.1dB (+/- 3dB range). The default setting is "**+0.0**".

**RMBL FILT:**

Enables (**On**) or disables (**Off**) the rumble filter for the phono input.

The **Mark Levinson Phono Rumble Filter** is a M-S (Mid-Side) filter designed to cut unwanted, sub-audible low-frequency (typically below 20-50Hz) noise created by turntable motors or warped LP records. The **Mark Levinson N° 626** combines both channels at very low frequencies, targeting the out-of-phase vertical signals (rumble) while preserving in-phase horizontal (musical) signal information without affecting the audible bass range. "L-R" signal attenuation is 3dB at 50Hz and 13dB at 10Hz.

While this noise is typically below the threshold of human hearing, it can cause excessive woofer cone movement which can impact the available headroom in your system.

**LOAD (MM):**

Selects the desired capacitive load for the **phono input** when **MM** is selected. The values that can be selected are: **50 pF, 100 pF (default), 150 pF, 200 pF, 250 pF, 300 pF, 350 pF & 400 pF**. See the **Helpful Hints** section on page 19 for additional information on selecting a **Load** for **MM**.

**LOAD (MC):**

Selects the desired impedance load for the phono input when **MC** is selected. The values that can be selected are: **20 Ω, 33 Ω, 50 Ω, 66 Ω, 100 Ω (default), 200 Ω, 330 Ω, 500 Ω, 1000 Ω**. See the **Helpful Hints** section on page 19 for additional information on selecting a **Load** for **MC**.

**FILT:**

Configures the filter characteristics used during digital to analog conversion as the signal passes through the **PrecisionLink III D/A converter**. The options are:

**Fast Apodizing, Fast Linear, Slow Linear, Fast Minimum, Slow Minimum, Phase Minimum, and Fast Phase Minimum.**

See the **Choosing a Digital to Analog Conversion Filter** section on page 22 for more details on the filter options.

**PLL LOCK:**

Sets the configuration of the **PLL Lock function**. **Normal (Norm)** or **Wide**. **Wide** is preferred for cable and satellite set-top boxes.

## AUDIO SETUP

The **Audio Setup** Menu allows for the configuration of the audio parameters as shown below.

Setup Menu	Audio	Setting	Increment	Range
SYSTEM	Balance	<--L/R-->	+/- 0.5 or -∞	-11.5dB L / -11.5dB R
AUDIO	Max Volume	Max Volume=100	+/- 1.0	40-100
INPUTS	Mute	Mute=Full	N/A	Partial (-18dB)/Full
	On Vol: <value>	On Vol=Last	+/- 1.0	Last/40-100
	On Input: <value>	On Input = Last	N/A	Last/A1 BAL/D1 USB...
	XLR Out: <value>	XLR Out=Vari	N/A	Vari/Fixed/HiPass
	RCA Out: <value>	RCA Out=Vari	N/A	Vari/Fixed/HiPass
	Volume: <value>	Volume=Normal	N/A	Normal/External
	POL: <value>	POL=Normal	N/A	Normal/Inverting
	SSP: <value>	SSP=Off	N/A	Off/A1 BAL/A2 BAL...
	HP On Vol: <value>	HP On Vol=Last	+/- 1.0	Last/40-100
	HP Imp: <value>	HP Imp=High Ω	N/A	High/Low
	HP Bal	<--HP Bal-->	+/- 0.1	-3.0dB L / -3.0dB R

### BALANCE:

Adjusts the **L/R balance** in steps of 0.5 up to 11.5dB. For the next step after 11.5, the display will show **R MAX** or **L MAX** and the opposite channel will be muted. The default setting is **"+0.0"**.

**Note:** If **Balance** is selected for the **Function button** operation, the **L/R remote buttons** will adjust the **balance**. This is the default setting.

### MAX VOLUME:

Sets the ceiling for the **maximum volume** that can be selected using the **remote/front panel volume encoder** (40-100).

The default setting is **"100"**.

### MUTE:

Sets the **Mute** function to either **Partial** (-18dB attenuation) or **Full** (maximum attenuation). The default setting is **"Full"**.

### ON VOL:

Determines the **volume** at which the **N° 626** will start at power-up (**Last** = volume level when put into standby). The default setting is **"Last"**.

### ON INPUT:

Determines the **input** which will be selected at power-up (**Last** = the input that was active when the **N° 626** was put into standby). The default setting is **"Last"**.

**XLR OUT:**

**Vari (Variable):** This is the default operation mode of the preamplifier. It allows normal operation of the **volume control(s)**.

**Fixed:** Locks the output level to **Volume Level 67 (unity gain)** and prevents volume changes by the user.

**CAUTION:** careful use of this mode is required to avoid damage to your audio system.

**Hi Pass:** A **4th order 80Hz Linkwitz-Riley high pass filter** is applied to the **XLR outputs** for use with a powered subwoofer.

**RCA OUT:**

**Vari (Variable):** This is the default operation mode of the preamplifier. It allows normal operation of the volume control(s).

**Fixed:** Locks the **output level** to **Volume Level 67 (unity gain)** and prevents volume changes by the user.

**CAUTION:** careful use of this mode is required to avoid damage to your audio system.

**Hi Pass:** A **4th order Linkwitz-Riley high pass filter** is applied to the **RCA outputs** for complementary use with a subwoofer.

**VOLUME:**

Determines whether the **volume** is controlled by the preamplifier or by an external **Mark Levinson** device.

**Normal (default):** sets the volume control to **Internal** so that the volume level is controlled by the **N° 626**.

**External:** sets the **volume** to be controlled by the network audio player. When this is selected, **internal volume control** is disabled, and the display follows the network audio player **volume setting**.

**Note:** The **N° 626** and the network audio player must be connected via the **Link** connection for **External** control to function.

**POL:**

Sets the **polarity** of the output. **Normal (default)** = 0 degrees, **Inverted** = 180 degrees.

**Note:** If the **Function button** is set to **POL**, pressing **Function** will display the current **polarity setting**. Pressing again will flip the **polarity**.

**SSP (SURROUND SOUND PROCESSOR) MODE:**

Sets one of the analog inputs as the **SSP input**, or disables **SSP** for all inputs. The default setting is **Off**. For more information, see the **SSP Mode** section of this document on **page 20**.

**HP ON VOL:**

Determines the **volume level** of the **N° 626** each time that headphones are newly connected.

**Last (default):** sets the **volume** to the level that was selected when headphones were last connected.

**40-100:** sets a specific **volume level** to be set each time headphones are newly connected.

**HP IMP:**

Determines the **output impedance** of the **headphone output**. **High  $\Omega$**  = 75  $\Omega$  (default), **Low  $\Omega$**  < 3  $\Omega$ .

**HP BAL:**

When headphones are connected, adjusts the **L/R balance** in steps of 0.1dB up to 3.0dB. The default setting is **"+0.0"**.

## SYSTEM SETUP

The **System Setup** Menu allows for the configuration of the **system parameters** as shown below.

### PRODUCT INFO:

Displays the **model number**, **serial number**, and **firmware version**.

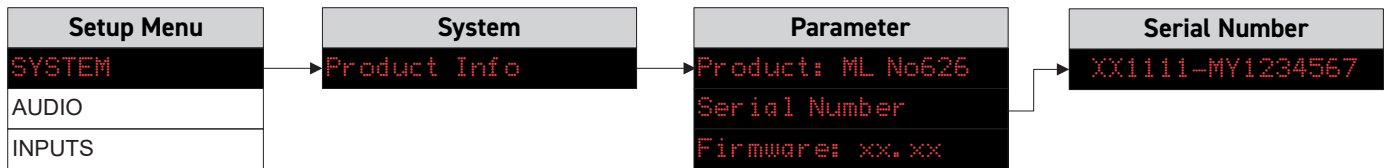

### STANDBY MODE:

**ECO On** (default) - Enables Music Sense, which puts the unit into **standby** when no music is detected for 20 minutes.

**ECO Off** - The **N° 626** will not enter standby mode unless engaged using the **front panel** or the **remote control**.

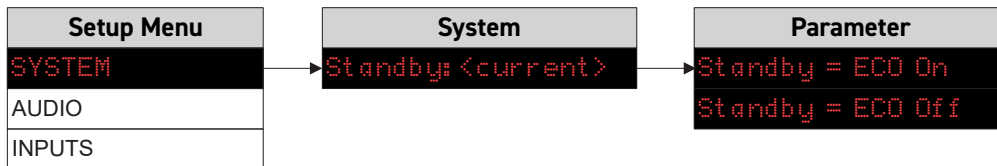

### FACTORY RESET:

If selected, the **N° 626** will enter **standby** and return to out-of-box conditions. To resume operation after resetting, press **Standby**.

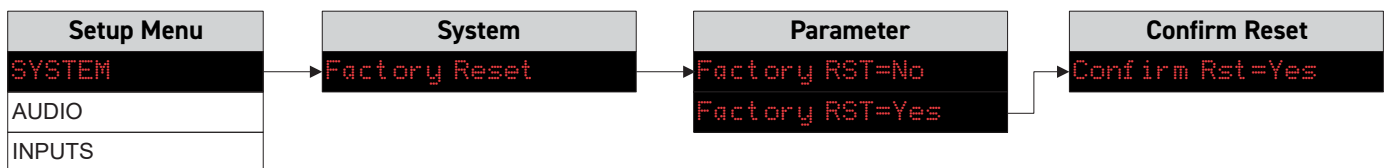

### TRIGGER IN:

**Normal** (default) - The **N° 626** will wake upon receiving a **12V trigger signal**, and the **input** will be the last selected input.

**Input** - When a **12V trigger signal** is received, the **N° 626** will power-on with the selected input active (**A2 BAL**, **D1 USB**, etc.).

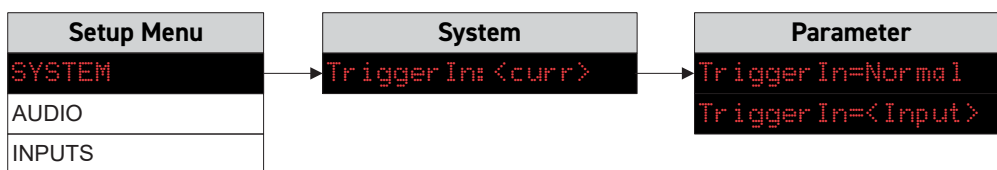

**RC CODE:**

Configures the **receiving code** for use with an **IR remote control**. The most common use-case for changing the **RC code** is to prevent neighboring IR devices and/or their remote controls from interfering with each other.

**16** (default)- Sets the code to **RC05-16** (default setting; compatible with the **remote control** default setting).

**Note:** to set the remote control to the **RC05-16** transmitting code, follow this procedure:

- First, press and hold the **Enter** and **Preamp** buttons on the **remote control** for 3 seconds (until the **LED** goes solid red)
- Then, press the **left arrow** of the **remote control D-pad**.

**Legacy - NEC** (for compatibility with some legacy **Mark Levinson remote controls**)

**19** - Sets the code to **RC05-19**.

**Note:** if you switch to this **RC Code** and wish to continue using the included **remote control**, the following procedure must be followed to change the **remote control** to transmit **RC05-19**, as both the **N° 626** and the **remote control** need to be set to the same **IR code**:

- First, press and hold the **Enter** and **Preamp** buttons on the **remote control** for 3 seconds (until the **LED** goes solid red).
- Then, press the **right arrow** of the **remote control D-pad**. This will set the **RC Code** of the **remote control** to **RC05-19** as well.

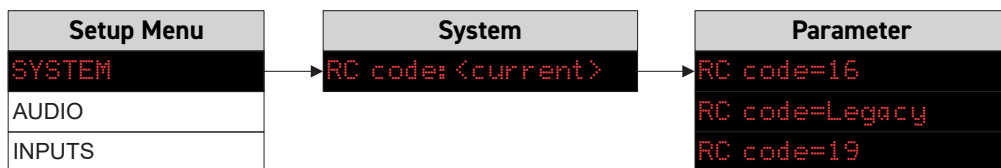

**FRONT IR:**

Enables (**On**) or Disables (**Off**) the **IR control input** on the **front panel**. The default setting is **On**.

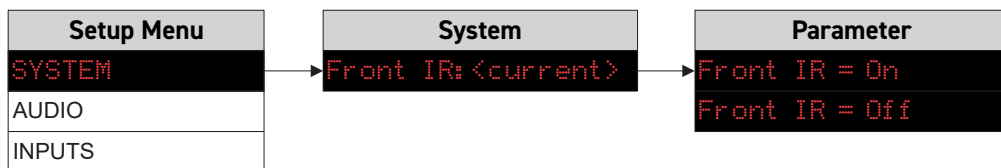

**FUNCTION:**

Determines which **function** is assigned to the front panel **Function button**: **Balance** (default), **Polarity**, or **Display Brightness**.

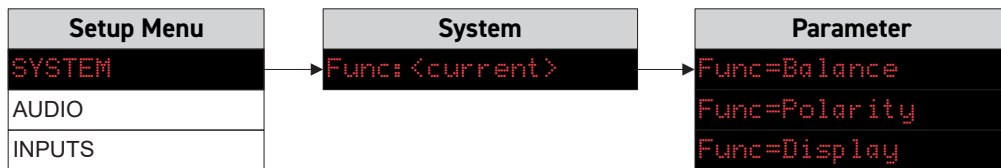

## SYSTEM SETUP (CONTINUED)

### ACCENT LIGHTING:

Determines the brightness of the **Tectonic accent lighting** such as the **top core element** and the **lights** on either side of the **front display**. Available settings are **High** (default), **Low**, or **Off**.

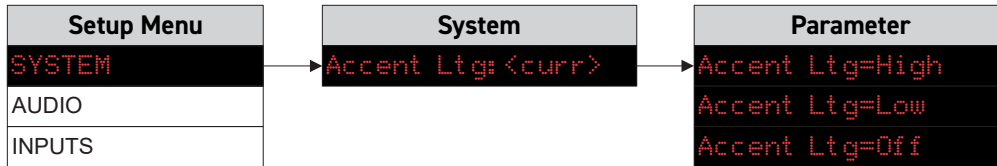

### DISPLAY BRIGHTNESS:

Determines the **brightness** of the **front panel display**: **High** (default), **Medium**, **Low**, or **Off**. When **Disp Bright** is assigned to the **Function button**, pressing it once will display the **current setting**. Each additional button press will cycle through the **brightness settings**.

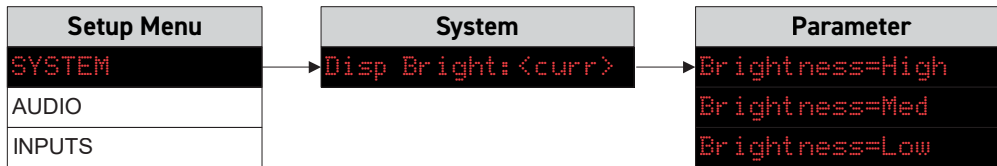

### DISPLAY TIMER:

Defines the length of time in seconds that the **display** remains lit after the last action. The default setting is **Disp timer Off**, which means that the **display** stays lit as long as the **preamplifier** is powered on (not in standby).

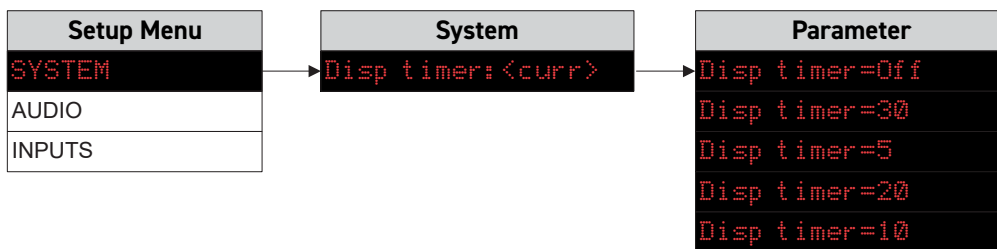

## HELPFUL HINTS

### DETERMINING THE LOAD FOR THE PHONO INPUT

The **N° 626 Class A phono stage** provides precise loading controls to optimize performance with both **Moving Magnet (MM)** and **Moving Coil (MC)** cartridges. See below for more information on how to calibrate these controls.

#### **MOVING MAGNET (MM) LOADING:**

MM cartridges have relatively high inductance, which interacts with cable and preamp capacitance to form a resonant circuit. Selecting the correct capacitive load helps maintain a smooth, accurate treble response. Begin with the cartridge manufacturer's recommended capacitance range. Add the capacitance of your tonearm wiring and interconnects, then select the closest value on the **N° 626** to remain within that range. From there, fine-tune by ear: if it is set too low, audio content will sound thin or bright; if it is set too high, audio content will sound dull or rolled-off.

#### **MOVING COIL (MC) LOADING:**

For MC cartridges, correct impedance loading ensures proper damping of the coil, smooth high-frequency behavior, and natural tonal balance. Start with the manufacturer's recommended load and adjust in small steps: increasing the value typically brightens the sound; decreasing it produces a fuller but potentially duller presentation.

#### **MC GAIN SETTING:**

Select **High Gain** for low-output MC cartridges (typically 0.2–0.5 mV) and **Low Gain** for high-output MC types (2–5 mV). If gain is set too low, playback may sound flat with more noise. If set too high, distortion may occur during loud passages. Final adjustments should be made by ear using familiar recordings.

## RENAMING INPUTS

#### **LIST:**

This option provides a pre-configured list of common names that you may wish to utilize.

#### **RESET:**

This option allows you to reset the name of the **input** to the default (out-of-box) setting.

#### **CUSTOM:**

This option allows you to create a **custom name** for any input.

Press **Enter** to select the **input** to be renamed. The first character position will begin blinking. Using the **Volume knob** or **Up/Down** on the **remote**, change the letter. Using the **Input knob** or **Left/Right** on the **remote**, select the next character position (if desired). This position will now begin blinking (it may appear blank). Using the **Volume knob** or **Up/Down** on the **remote**, change the letter. Repeat this process until the renaming is complete. Press **Enter** to save.

While under normal operation, to see how the current name of an **input** corresponds to its physical **input connector**, press the **Info** button.

## SSP MODE

### SURROUND SOUND PROCESSOR (SSP) MODE

Integrating two-channel components with multichannel systems has traditionally been challenging. In a multichannel processor, the volume control adjusts all channels together. As the left/right channels pass through a stereo preamplifier, their levels are affected. This causes a relative level difference between the left/right channels and the rest of the channels. **SSP Mode (Surround Sound Processor Mode)** eliminates this issue by allowing the processor's left/right channels to pass through the preamplifier without any level modification. When **SSP Mode** is active, the **preamplifier's volume control** is disabled. This ensures that the system maintains its properly calibrated channel levels.

To connect the preamp with a surround sound processor:

1. Make sure the **preamplifier** and all associated components are powered off and disconnected from electrical outlets.
2. Connect the output connectors on the surround-sound source component to the input connectors on the surround-sound processor. For example, if the source component is an optical video disc player, connect it to the appropriate input connectors on the surround sound processor.
3. Connect the front left and right output connectors on the processor to the desired **analog input connectors** on the **Nº 626**. For best performance, use balanced connections whenever possible.
4. Connect the center, surround, and subwoofer output connectors on the processor to the appropriate input connectors on the power amplifier(s).
5. Connect the **preamplifier's outputs** to the amplifier(s) connected to the system's left and right (main) speakers.

**CAUTION:** Before activating the SSP mode for any input, set the associated surround sound processor volume control to a reasonable level to prevent sending dangerously high signal levels to the associated loudspeakers.

#### TO ACTIVATE SSP MODE FOR THE SELECTED ANALOG INPUT:

1. Activate the **Setup Menu** by pressing the **Setup button**
2. Select **AUDIO**, and press **Enter**
3. Select **SSP**, and press **Enter**
4. Select the **analog input** you wish to configure for **SSP** use, and press **Enter**
5. Press the **Home button** to exit the **Setup Menu**, or press the **Setup button** to navigate up one level in the **menu**.

### SSP EXAMPLE USING A1 BAL INPUT

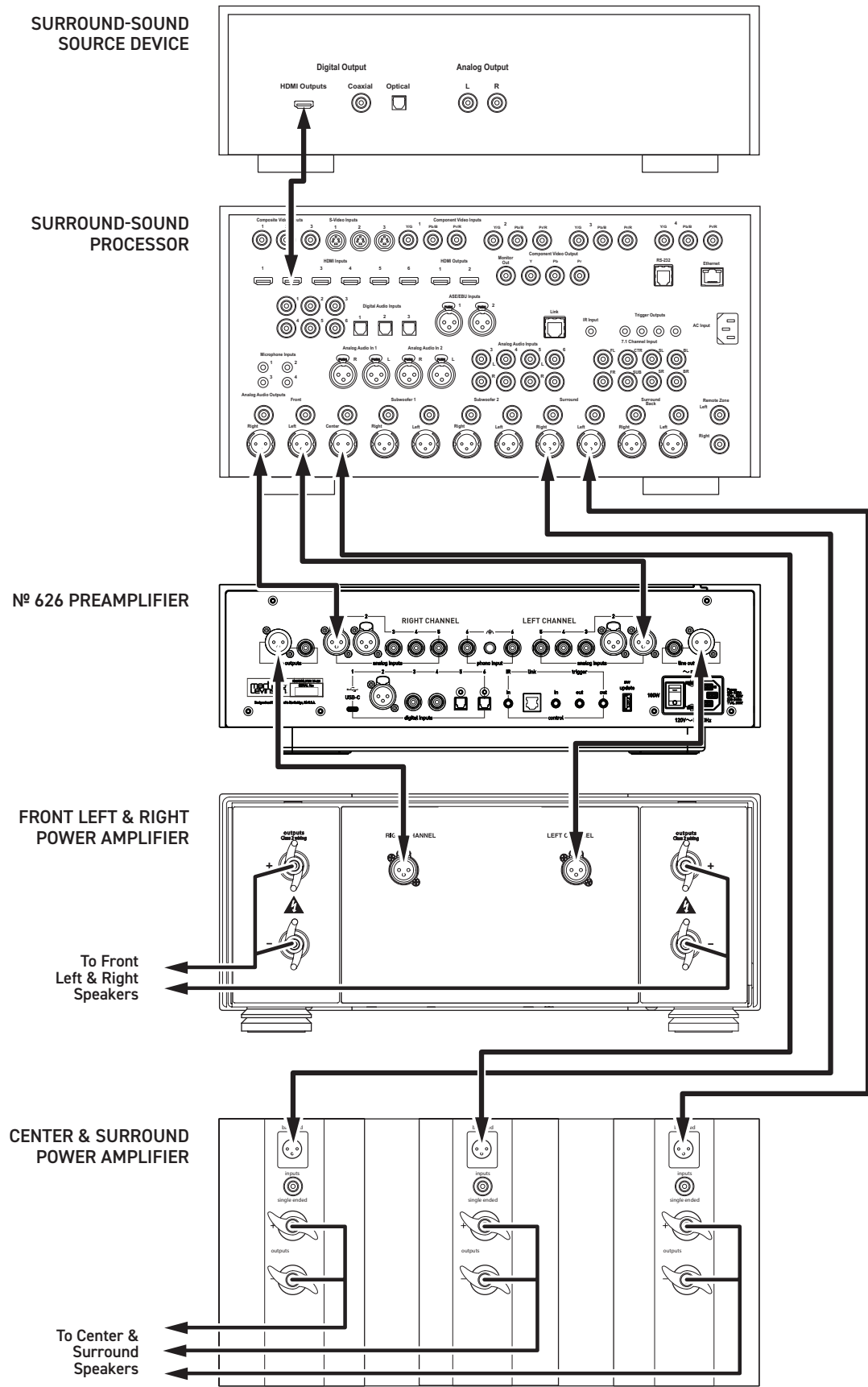

# CHOOSING A DIGITAL TO ANALOG CONVERSION FILTER

Each **digital input** offers **7 user-selectable filters** allowing the most discerning listeners to tune the **D/A filters** to their own personal taste or to the character of the content. Note that the effect will be subtle, and that there are no right or wrong choices when it comes to your preference. To configure a **digital input filter setting**, press **Setup**, select the desired **digital input name**, and select the **Filter** option. You may then choose between the following filters.

## CHOOSING THE RIGHT FILTER:

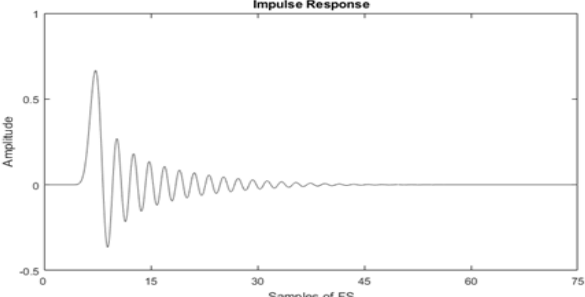
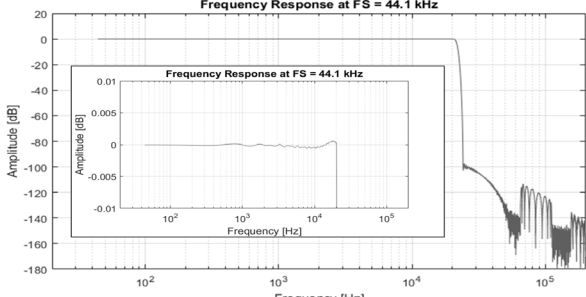
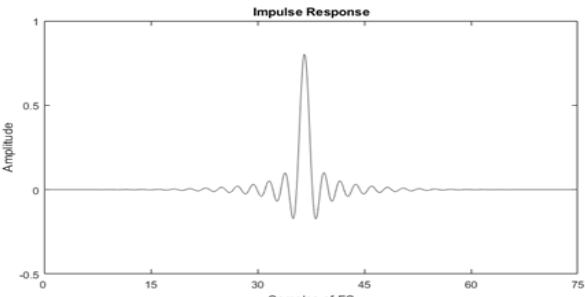
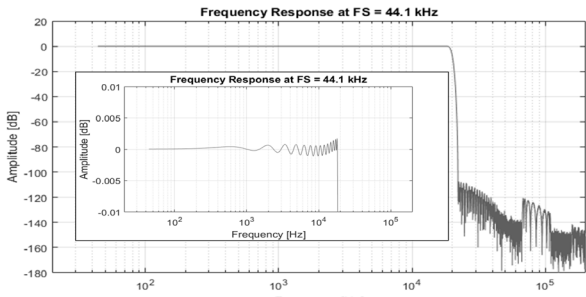
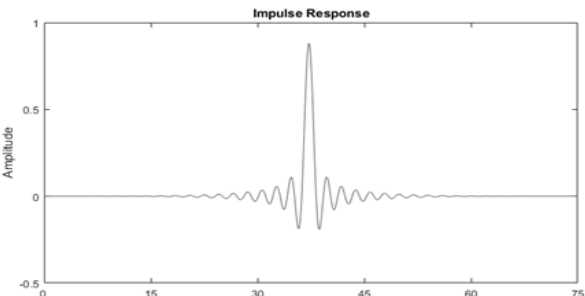
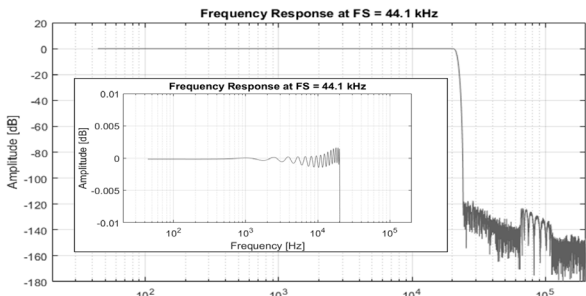
FILTER TYPE	PROS	SUGGESTED USE-CASE
<p><b>Ph Min =</b> <b>Minimum Phase</b></p>	<ul style="list-style-type: none"> <li>- no pre-ringing (more natural transient response)</li> <li>- lower latency</li> </ul>	<p>natural, analog-like sound; preferred in vocal and acoustic music</p>
		
<p><b>F Apodiz =</b> <b>Linear Phase Apodizing</b></p>	<ul style="list-style-type: none"> <li>- reduces upstream ringing from mastering</li> <li>- balanced impulse response</li> <li>- smooth treble</li> </ul>	<p>clean playback of mastered content; good for resolving sibilance</p>
		
<p><b>F Lin =</b> <b>Linear Phase Fast Roll-off</b></p>	<ul style="list-style-type: none"> <li>- sharp cutoff</li> <li>- excellent suppression of aliasing</li> <li>- preserves frequency accuracy</li> </ul>	<p>analytical listening; high-resolution playback where precision matters</p>
		

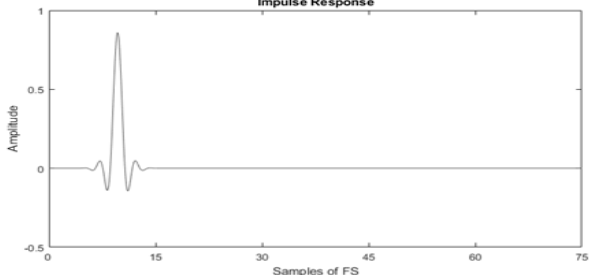
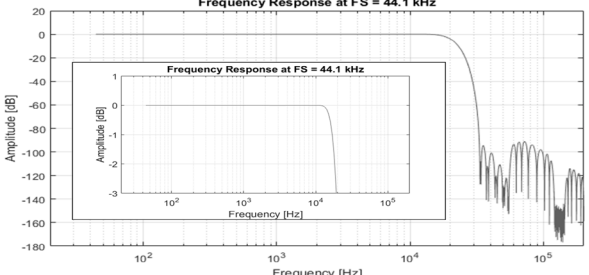
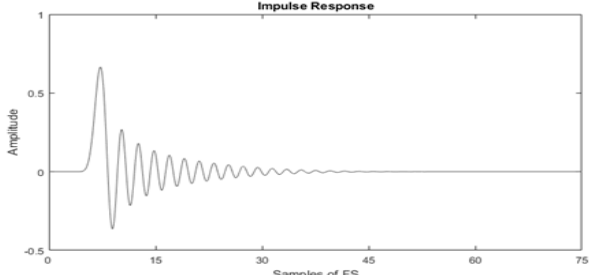
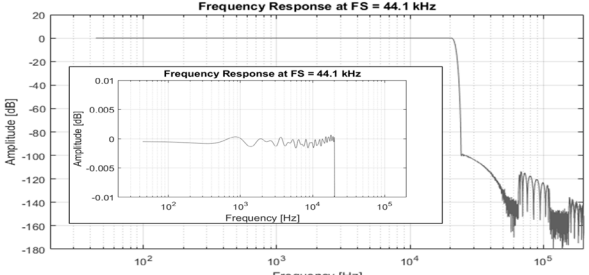
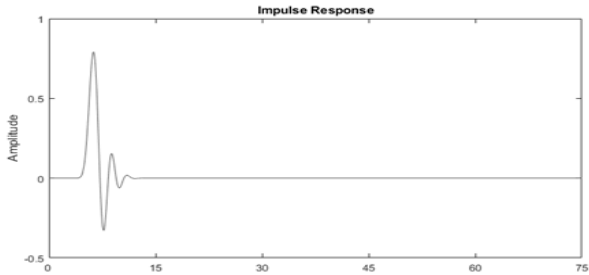
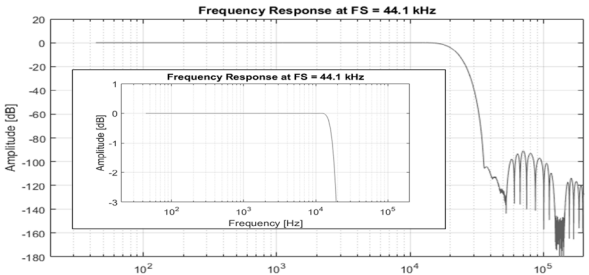
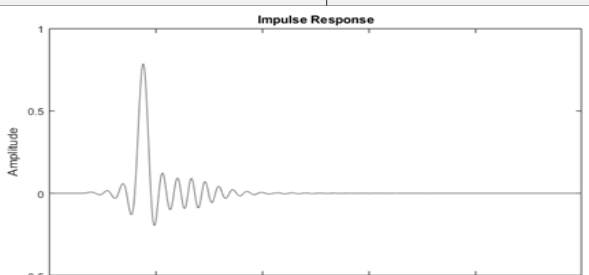
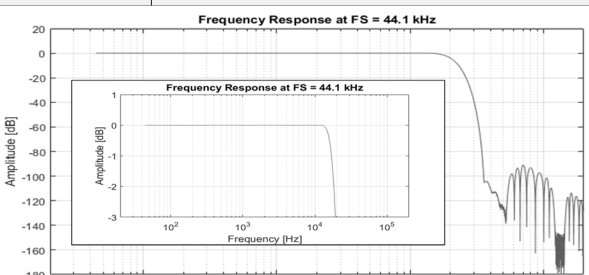
FILTER TYPE	PROS	SUGGESTED USE-CASE
<p><b>S Lin =</b> Linear Phase Slow Roll-off</p>	<ul style="list-style-type: none"> <li>- gentler cutoff</li> <li>- less pre-ringing</li> <li>- smoother sound</li> </ul>	<p>relaxed listening; warmer sound signature</p>
		
<p><b>F Min =</b> Minimum Phase Fast Roll-off</p>	<ul style="list-style-type: none"> <li>- fast attenuation of unwanted frequencies</li> <li>- no pre-ringing</li> <li>- balanced clarity and naturalness</li> </ul>	<p>balanced sound; good for general listening and modern recordings</p>
		
<p><b>S Min =</b> Minimum Phase Slow Roll-off</p>	<ul style="list-style-type: none"> <li>- very smooth and natural sound</li> <li>- minimal artifacts</li> <li>- no pre-ringing</li> </ul>	<p>warm, analog-like sound; ideal for long listening sessions</p>
		
<p><b>F PhMin =</b> Minimum Phase Slow Roll-off Low Dispersion</p>	<ul style="list-style-type: none"> <li>- most natural impulse response</li> <li>- very low time-domain distortion</li> <li>- no pre-ringing</li> </ul>	<p>audiophile-grade listening; best for high-res recordings and acoustic music</p>
		

## TROUBLESHOOTING

Incorrect operation is sometimes mistaken for malfunction. If problems occur, see this section for troubleshooting information. If problems persist, please contact your **Mark Levinson** dealer or **Mark Levinson Customer Support**.

### NO POWER

Examine the **power cord** to ensure that it is connected to both the **AC mains connector** and a functioning electrical outlet.

Make sure the **preamp** is powered on with the **rear-panel Power switch**. Examine the electrical circuit breaker to ensure that power is being supplied to the electrical outlet to which the **preamp** is connected.

Make sure the **preamp** is not in **standby**. The **front-panel standby LED** illuminates bright red when the preamplifier is **On**. The **LED** illuminates dim red when the **preamp** is in **Standby mode**.

### REMOTE CONTROL DOES NOT OPERATE

Try operating the remote control again after pressing the **Preamp** button (the button in the center of the top row on the remote control) if you are having trouble controlling the **Nº 626** via **remote control**.

Eliminate obstructions between the **remote control IR transmitter** and the **IR receiver** on the **front-panel display**. Make sure the **rear-panel IR input connector** is not being used.

Make sure the **remote control** is positioned within 17 feet (5m) of the **front panel**. If the **preamp** is placed inside a **glass cabinet**, tinted glass will reduce the **remote control range**.

Make sure the **remote control** signal is being received at the **IR receiver** on the **front-panel display** at a reasonable angle.

Make sure the **IR receiver** on the **front-panel display** is not exposed to strong sunlight, halogen light, or fluorescent light. This can cause IR reception to become unreliable.

Replace the **remote control** batteries.

### NO SIGNAL AT THE OUTPUTS

Examine all audio cables to ensure a solid connection between the **preamplifier** and all associated components. Examine the speaker cables to ensure a solid connection between the speakers and the amplifiers. Make sure that the connected speakers are operational. Make sure the **volume** is set to an audible level.

Make sure the **mute** is deactivated. Make sure the **Offset** setting for the selected **input** is not reducing the **volume** to an inaudible level. Make sure all associated components are connected to working electrical outlets and powered on. Make sure the source device connected to the **preamp's** selected **input** is producing an output signal.

## LIST OF INPUTS IS MISSING AN INPUT

Make sure that the “**Disable**” parameter in the **Input Setup Menu** is not set to **YES** for the **input** in question.

## DIGITAL AUDIO DROPOUTS

Set **PLL Lock** to **Wide**.

## AUDIO HUM

Disconnect components one at a time to isolate the problem.

Once the problem is identified, make sure the problematic component is properly grounded and connected to the same electrical circuit as the preamp.

## VOLUME CAN'T BE SET TO MAXIMUM

You have the option of establishing a **maximum volume level** in the **Setup Menu**. If this option is set, it can prevent the unit's **maximum volume level** of **100** from being reached. Refer to **Volume Control / MaxVol** for more information.

## IF ALL ELSE FAILS...

Power cycle the **preamp** with the **rear-panel Power switch**, waiting at least 30 seconds between powering the unit off and on.

Restore factory-default settings (See **System Setup, Factory Reset** on page 16).

Contact your authorized **Mark Levinson** dealer.

Contact **Mark Levinson Customer Service** at [support.harmanluxuryaudio.com](mailto:support.harmanluxuryaudio.com).

## MARK LEVINSON Nº 626 SPECIFICATIONS

<b>GAIN</b>	
VARIABLE MODE MAX GAIN	13.5DB BALANCED; 7.5DB SINGLE-ENDED
FIXED MODE GAIN	3.0DB BALANCED; -3.0DB SINGLE-ENDED
<b>FREQUENCY RESPONSE</b>	
20HZ TO 20KHZ	+0.2DB / -0.02DB
0.4HZ TO 150KHZ	+0.1 / -2DB
<b>TOTAL HARMONIC DISTORTION PLUS NOISE (THD+N)</b>	
AT 1KHZ (2VRMS SINGLE-ENDED OR 4VRMS BALANCED OUTPUT)	<0.003%
AT 20KHZ (2VRMS SINGLE-ENDED OR 4VRMS BALANCED OUTPUT)	<0.005%
<b>SIGNAL-TO-NOISE RATIO</b>	
20HZ TO 20KHZ, WIDEBAND, UNWEIGHTED	>97DB (2VRMS SINGLE-ENDED OR 4VRMS BALANCED OUTPUT)
A-WEIGHTED	>100DB (2VRMS SINGLE-ENDED OR 4VRMS BALANCED OUTPUT)
<b>CROSSTALK</b>	
AT 1KHZ	BELOW NOISE FLOOR (UNUSED INPUTS TERMINATED)
AT 20KHZ	BELOW NOISE FLOOR (UNUSED INPUTS TERMINATED)
<b>RCA INPUTS</b>	
INPUT IMPEDANCE	>45K $\Omega$
MAXIMUM INPUT LEVEL	NORMAL GAIN SETTING: >10VRMS, HIGH GAIN SETTING: >7VRMS
<b>XLR INPUTS</b>	
INPUT IMPEDANCE	>45K $\Omega$
MAXIMUM INPUT LEVEL	NORMAL GAIN SETTING: >15VRMS, HIGH GAIN SETTING: >7.5VRMS
<b>RCA OUTPUTS</b>	
OUTPUT IMPEDANCE	<80 $\Omega$
MAXIMUM OUTPUT LEVEL	>11VRMS
<b>XLR OUTPUTS</b>	
OUTPUT IMPEDANCE	<160 $\Omega$
MAXIMUM OUTPUT LEVEL	>22VRMS
<b>HEADPHONE OUTPUT</b>	
OUTPUT IMPEDANCE (LOW IMPEDANCE SETTING)	<3 $\Omega$
OUTPUT IMPEDANCE (HIGH IMPEDANCE SETTING)	75 $\Omega$
MAXIMUM OUTPUT, LOW IMPEDANCE SETTING	>3VRMS (30 $\Omega$ (0.3W), 20HZ TO 20KHZ, <0.1% THD)
MAXIMUM OUTPUT, HIGH IMPEDANCE SETTING	>7VRMS (300 $\Omega$ , 20HZ TO 20KHZ, <0.01% THD)
TOTAL HARMONIC DISTORTION PLUS NOISE (THD+N)	<0.03% (20HZ TO 20KHZ, 2VRMS AT 30 $\Omega$ )
	<0.01% (20HZ TO 20KHZ, 2VRMS AT 300 $\Omega$ )
<b>OTHER LINE STAGE</b>	
CHANNEL SEPARATION	BELOW NOISE FLOOR (UNUSED INPUTS TERMINATED)
HIGH-PASS FILTER	DEFEATABLE 80HZ, 4TH ORDER (24DB/OCTAVE) LINKWITZ-RILEY
VOLUME CONTROL	BALANCED, CURRENT MODE, DISCRETE 15-BIT R-2R LADDER
<b>PHONO STAGE</b>	
RIAA FREQUENCY RESPONSE	20HZ TO 20KHZ, $\pm$ 0.3DB
INFRASONIC FILTER	DEFEATABLE, 15HZ, 2ND ORDER (12DB/OCTAVE)

MOVING MAGNET MODE	
INPUT RESISTANCE	47KΩ
INPUT CAPACITANCE	SELECTABLE; 50, 100, 150, 200, OR 680PF
GAIN	40DB @ 1KHZ
TOTAL HARMONIC DISTORTION PLUS NOISE	<0.03%, 20HZ TO 20KHZ, 2VRMS OUTPUT
SIGNAL-TO-NOISE RATIO (REFERRED TO 2VRMS OUTPUT)	>97DB (20HZ TO 20KHZ, WIDEBAND, UNWEIGHTED)
	>102DB (A-WEIGHTED)
	>110DB @ 20HZ TO 20KHZ (SPOT NOISE)
MAXIMUM INPUT LEVEL	>95MV @ 1KHZ; >285MV @ 20KHZ
MOVING COIL MODE	
INPUT RESISTANCE	SELECTABLE; 20, 33, 50, 66, 100, 200, 330, 500, 1000, OR 47KΩ
INPUT CAPACITANCE	50PF
GAIN	SELECTABLE; HIGH = 70DB, LOW = 60DB @ 1KHZ
TOTAL HARMONIC DISTORTION PLUS NOISE	50DB GAIN SETTING: <0.02%, 20HZ TO 20KHZ, 2VRMS OUTPUT
	60DB GAIN SETTING: <0.02%, 20HZ TO 20KHZ, 2VRMS OUTPUT
	70DB GAIN SETTING: <0.04%, 20HZ TO 20KHZ, 2VRMS OUTPUT
SIGNAL-TO-NOISE RATIO (REFERRED TO 2VRMS OUTPUT)	50DB GAIN SETTING: >87DB (20HZ TO 20KHZ, WIDEBAND, UNWEIGHTED)
	50DB GAIN SETTING: >94DB (A-WEIGHTED)
	50DB GAIN SETTING: >100DB AT 20HZ TO 20KHZ (SPOT NOISE)
	60DB GAIN SETTING: >77DB (20HZ TO 20KHZ, WIDEBAND, UNWEIGHTED)
	60DB GAIN SETTING: >84DB (A-WEIGHTED)
	60DB GAIN SETTING: >90DB AT 20HZ TO 20KHZ (SPOT NOISE)
	70DB GAIN SETTING: >68DB (20HZ TO 20KHZ, WIDEBAND, UNWEIGHTED)
	70DB GAIN SETTING: >74DB (A-WEIGHTED)
	70DB GAIN SETTING: >80DB AT 20HZ TO 20KHZ (SPOT NOISE)
MAXIMUM INPUT LEVEL	50DB GAIN SETTING: >30MV @ 1KHZ; >105MV @ 20KHZ
	60DB GAIN SETTING: >9.5MV @ 1KHZ; >90MV @ 20KHZ
	70DB GAIN SETTING: >3.2MV @ 1KHZ; >30MV @ 20KHZ
DIGITAL-TO-ANALOG CONVERTER	
OUTPUT VOLTAGE	3.7VRMS @ FULL SCALE (0DBFS)
FREQUENCY RESPONSE	20HZ TO 20KHZ, +0 / -0.2DB
TOTAL HARMONIC DISTORTION	<0.0001% @ 1KHZ, FULL SCALE (0DBFS)
	<0.0003% @ 20KHZ, FULL SCALE (0DBFS)
SIGNAL-TO-NOISE RATIO (REFERRED TO 3.7VRMS / 0DBFS OUTPUT)	>117DB (20HZ TO 20 KHZ, WIDEBAND, UNWEIGHTED)
	>120DB (A-WEIGHTED)
SAMPLE RATES/BIT-DEPTHS	
PCM	32, 44.1, 48, 88.2, 96, 176.4, 192KHZ, OR 384KHZ; UP TO 32 BITS
DSD	NATIVE OR DOP (DSD OVER PCM), SINGLE, DOUBLE, QUADRUPLE-SPEED (2.8, 5.6, 11.2MHZ). NATIVE DSD SUPPORTED WITH LINUX OR ANDROID BASED SOURCE DEVICES ONLY.

## SPECIFICATIONS

ANALOG AUDIO CONNECTORS	
LINE INPUTS	3x PAIR SINGLE-ENDED (RCA), 2x PAIR BALANCED (XLR)
PHONO INPUT	1x PAIR SINGLE-ENDED PHONO INPUTS (RCA), 1x PHONO GROUND BINDING POST
OUTPUTS	1x PAIR SINGLE-ENDED LINE (RCA), 1x PAIR BALANCED LINE (XLR), 1x TS 1/4" (6.3MM) HEADPHONE
DIGITAL AUDIO CONNECTORS	
BALANCED	1x AES/EBU (XLR)
COAXIAL	2x S/PDIF (RCA)
OPTICAL	2x TOSLINK
USB ASYNCHRONOUS	USB TYPE C (ASYNCHRONOUS)
CONTROL/SERVICE CONNECTORS	
LINK	1x RJ-12 CONNECTION FOR USE WITH FUTURE SOURCE DEVICE
INFRARED (IR)	1x 1/8" (3.5MM) PHONE JACK
DC TRIGGERS	2x 12V OUTPUTS (1/8" / 3.5MM PHONE JACK)
	1x 12V INPUT (1/8" / 3.5MM PHONE JACK)
SERVICE	1x USB-A (SOFTWARE UPDATE ONLY)
GENERAL	
MAINS VOLTAGE	100VAC, 120VAC, OR 230VAC (REGION SPECIFIC)
POWER CONSUMPTION ECO ON MODE (STANDBY)	<0.5W
POWER CONSUMPTION ECO OFF MODE (STANDBY)	75W
POWER ON, IDLE	80W
POWER ON, IDLE, HEADPHONES CONNECTED	85W
DIMENSIONS (W X D X H)	17.9" X 19.1" X 5.6" (455 X 484 X 142.5MM)
PACKAGING DIMENSIONS (W X D X H)	24.8" X 24.8" X 13.4" (630 X 630 X 340MM)
UNIT WEIGHT	37.7 LBS (17.1 KG)
WEIGHT WITH PACKAGING	57.1 LBS (25.9 KG)



HARMAN International Industries, Incorporated  
 8500 Balboa Boulevard  
 Northridge, CA 91329 USA

© 2026 HARMAN International Industries, Incorporated. All rights reserved.

Mark Levinson is a registered trademark of HARMAN International Industries, Incorporated. Other company and product names may be trademarks of the respective companies with which they are associated.

This document should not be construed as a commitment on the part of HARMAN International Industries, Incorporated. The information it contains, as well as the features, specifications and appearance of the product, is subject to change without notice. HARMAN International Industries, Incorporated, assumes no responsibility for errors that may appear within this document.

LS\_MarkLevinson\_No626\_OM\_EN\_v1\_4\_20260515

